



RB32

MINIBRUTE MAGNETIC DRILL PRESS



SAFETY / USAGE GUIDELINES

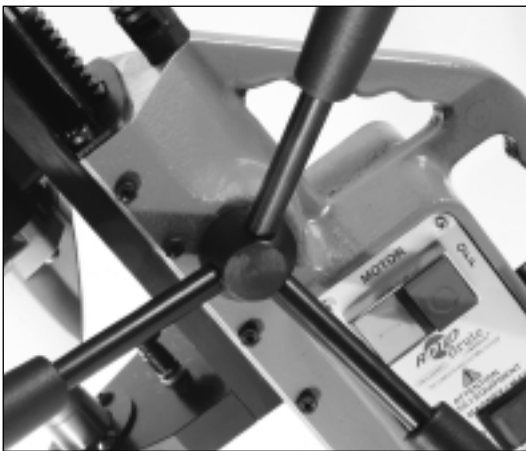

PARTS & SCHEMATICS



CHAMPION



RB32 MINIBRUTE

COMPONENTS & SAFETY

IMPORTANT

Please read these operating and safety instructions carefully and completely. For your own safety, before using this equipment check that the voltage is correct and that all handles and parts are firmly secured. If you are uncertain about any aspect of using this equipment, contact your distributor.

PLEASE KEEP THESE INSTRUCTIONS

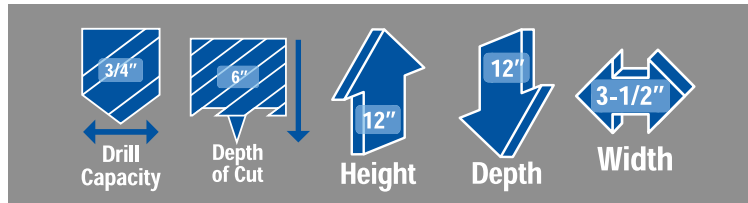
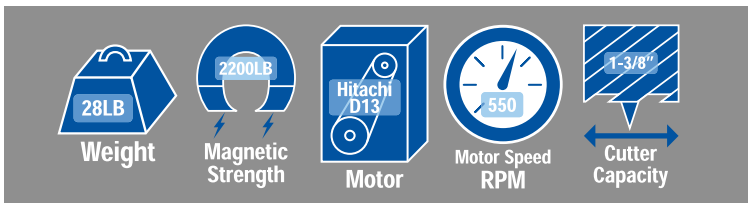

INCLUDED WITH EVERY RB32

Carrying case, safety strap, RB334 3/4" arbor, RB3212 1/2" drill chuck, D-handle, cutting fluid, safety guard, chuck key, hex keys and spanner wrenches

Ear and eye protection MUST be worn during operation of this equipment. Do NOT touch the cutter while it is in motion. Always follow the Personal Protection Equipment (PPE) recommendations while operating this tool.

This machine is designed specifically for drilling holes in steel using annular cutters or with twist drills when using the optional drill chuck. We recommend Champion® Rotobrute™ annular cutters. Please consult your Champion authorized distributor for a complete range of sizes.

DO NOT modify and / or use your Rotobrute™ magnetic drill press for any application other than for which it is intended.

SAFETY

Be sure to read and follow these important safety instructions:

When using your RB32 MiniBrute, be sure to follow these important safety precautions:

1. Before operating the machine, check supply voltage and general conditions, i.e. cable/cord damage. A machine with damaged cable must be returned or repaired prior to use.
2. Always use the safety strap in all drilling applications.
4. Since cutting tools can shatter, eye and head protection should be worn at all times.
5. After use, clean machine and cutters and keep in the case provided.
6. Store when not in use, in a dry environment.
7. Always provide a method of catching slug, where the ejected slug may cause injury (slug ejects at end of cut).
8. Should the cutter jam in the work-piece, stop the machine immediately. Isolate the machine at the main supply. Loosen the cutter by rotating the arbor. Do not attempt to free cutter by starting and stopping the motor.
9. Always use the safety guard provided.

Electrical Safety

1. Grounded tools must be plugged into an outlet properly installed and grounded in accordance with all codes and ordinances. Never remove the grounding prong or modify the plug in any way.
2. Do not use any adapter plugs. Check with a qualified electrician if you are in doubt as to whether the outlet is properly grounded. If the tools should electrically malfunction or breakdown, grounding provides a low resistance path to carry electricity away from the user.
3. Never use the cord to carry the tools or pull the plug from an outlet. Replace damaged cords immediately.
4. When operating a power tool outside, use an outdoor extension cord marked "W-A" or "W". These cords are rated for outdoor use and reduce the risk of electric shock. Minimal gauge external cord should be 12/3.
5. Use the RB-32 with 110 A/C voltage only. Not for use with generators, welders or any dc power source. Do not use on any surface where welding is taking place.

Personal Safety

Stay alert, watch what you are doing and use common sense when operating a power tool. Do not use tool while tired or under the influence of drugs, alcohol, or medication.

Do not wear loose clothing or jewelry. Avoid accidental starting. Be sure switch is off before plugging in. Carrying tools with your finger on the switch or plugging in tools that have the switch on invites accidents.

Remove adjusting keys before turning the tool on.

Do not overreach. Keep proper footing and balance at all times.

Safety equipment (eye protection, dust mask, nonskid safety shoes, hard hat, hearing protection) should be used for appropriate conditions.

Tool Use and Care

Use clamps or other practical ways to secure and support the work-piece to a stable platform.

Do not force tool. Use the correct tool for the application.

Disconnect the plug from the power source before making any adjustments, changing accessories, or storing the tool.

Store idle tools out of reach of children and other untrained persons.

Maintain tools with care. Keep cutting tools sharp and clean.

Check for misalignment or binding of moving parts, breakage of parts and any other condition that may affect the tool's operation. If damaged, have the tool serviced before using.

Service

Tool service must be performed only by qualified personnel.

When servicing a tool, use only original replacement parts.

Use of unauthorized parts will void the warranty.

Use of unauthorized parts or failure to follow maintenance instructions may create a risk of electric shock or injury.

Magnetic Drill Safety

The drill's magnetic adhesion depends on the thickness of the work-piece. 1/2" (13mm) is the minimum thickness for safe operation. Keep the magnet clean of metal chips and other dirt and debris. These will seriously reduce the magnetic adhesion. The drill must be operated on its own electrical outlet. Always use the supplied safety strap or chain. An electrical overload can result in loss of adhesion.

CAUTION: The slug ejects at end of cut and is very hot.

WARNING: Do not attempt to drill a work-piece, which is thicker than the maximum cutting depth of the cutter being used. **Never** exceed 1-3/8" (35mm) cutter diameter.

Maintenance and Troubleshooting

Keep the drill press and the cord clean. In case of electrical or mechanical malfunction, immediately switch off the tool and disconnect the plug. Excessive sparking generally indicates the presence of dirt in the motor or worn out carbon brushes. Periodically check brushes for wear and replace when they reach 1/4" (6mm). Also check that the machine is well lubricated.

For all other service and maintenance, please contact a Champion® authorized service center.



RB32

The RB32 is available in two other configurations:

RB32-VSR - The same features as the RB32 but has variable speed control and reverse. It also features an isolating power relay for improved handling safety. The RB32-VSR can run twist drills at the correct RPM and has optical attachments.

RB32-ECS - The same features as the RB32 with a built in external coolant system.

Please see Champion's website for additional technical information downloads on both these configurations.



Operating Instructions

1. Place a pilot pin in the cutter at the shank end. Insert the cutter into the special arbor, aligning the flats to the set screws on the arbor. Secure the set screws to the cutter with the supplied hex wrench.
2. Position the machine on a clean, dry, ferrous surface at least 1/2" thick. Switch on the magnet.
3. Cutting fluid must be used at all times to enhance the quality of cut and prolong the cutting tool life. Cutting fluid is applied through small holes located at the top/shank end of the arbor and feeds via gravity.
4. Switch on the drill. Always proceed with caution at the start of drilling operations. When using RotoBrute annular cutters apply pressure gradually at first until a depth of 1/8" is reached. Normal cutting pressure can then be applied.
5. On completion of cut, withdraw the cutter from hole, switch off the drill, then the magnet. Ensure the magnet base is clear of chips. Locate the next hole using the above procedures.

Adjusting Dovetail Slides

Slowly adjust the hex screws while moving the handle up and down. Adjust so there is no free play or no binding anywhere through its range of travel. Periodically check, lubricate, and adjust as necessary.

Repositioning of Handles

1. Elevate the slide upward to its full extent.
2. Remove the pinion cap screw and pinion cap from the shaft end (opposite side to handles).
3. Slide the pinion with the handles on outward, approximately 1/3rd distance.
4. Disengage the rack by means of raising the slide up by another 3/4".
5. Remove pinion, reposition through opposite side of body casting and reverse procedure as above.

Assembly of Arbor for use with Annular Cutters

1. Align arbor support bracket with holes on dovetail slide.
2. Align support screws with holes and tighten clockwise.
3. IMPORTANT - do NOT tighten all the way until arbor is in place.
4. Place arbor through center hole of support bracket, making sure spindle bushing collar is upright. Align with 1/2-20 threaded spindle and tighten clockwise.
5. When arbor is in place, tighten arbor support screws.
6. To remove arbor, use the 17mm wrench provided to hold the spindle nut in place. Use the 7/16" wrench to hold the flats while turning counter-clockwise to loosen.

Assembly of Drill Chuck for use with Straight Shank Tools

An important feature of the RB32 is that it can quickly and easily be converted to operate standard twist drills and other straight shank cutting tools such as chassis reamers. To remove the arbor assembly:

1. Use the included 5mm hex wrench to remove the two arbor support screws.
2. Loosen 3/4" arbor by unscrewing in counter-clockwise direction, using a wrench on flats located at top of arbor.
3. Remove arbor support bracket.
4. Screw on 3-jaw chuck, supplied, and install safety screw to prevent drill chuck from becoming frozen.
5. Insert twist drill or other straight shank cutting tool and tighten with chuck key. To remove drill chuck, reverse procedure.

Assembly of Traverse Handles

1. To assemble traverse handle, place each of the three (3) handles into the threaded holes on the pinion shaft, turning clockwise to tighten.
2. To remove handles, turn counter-clockwise.

Assembly of Safety Guard

- Loosen screw from underneath the arbor support (front/center). Align the bracket slot with the screw, and tighten screw until safety guard locks into place.
- To remove safety guard, loosen screw and remove safety guard.

RB32 ELECTRICAL DIAGRAM

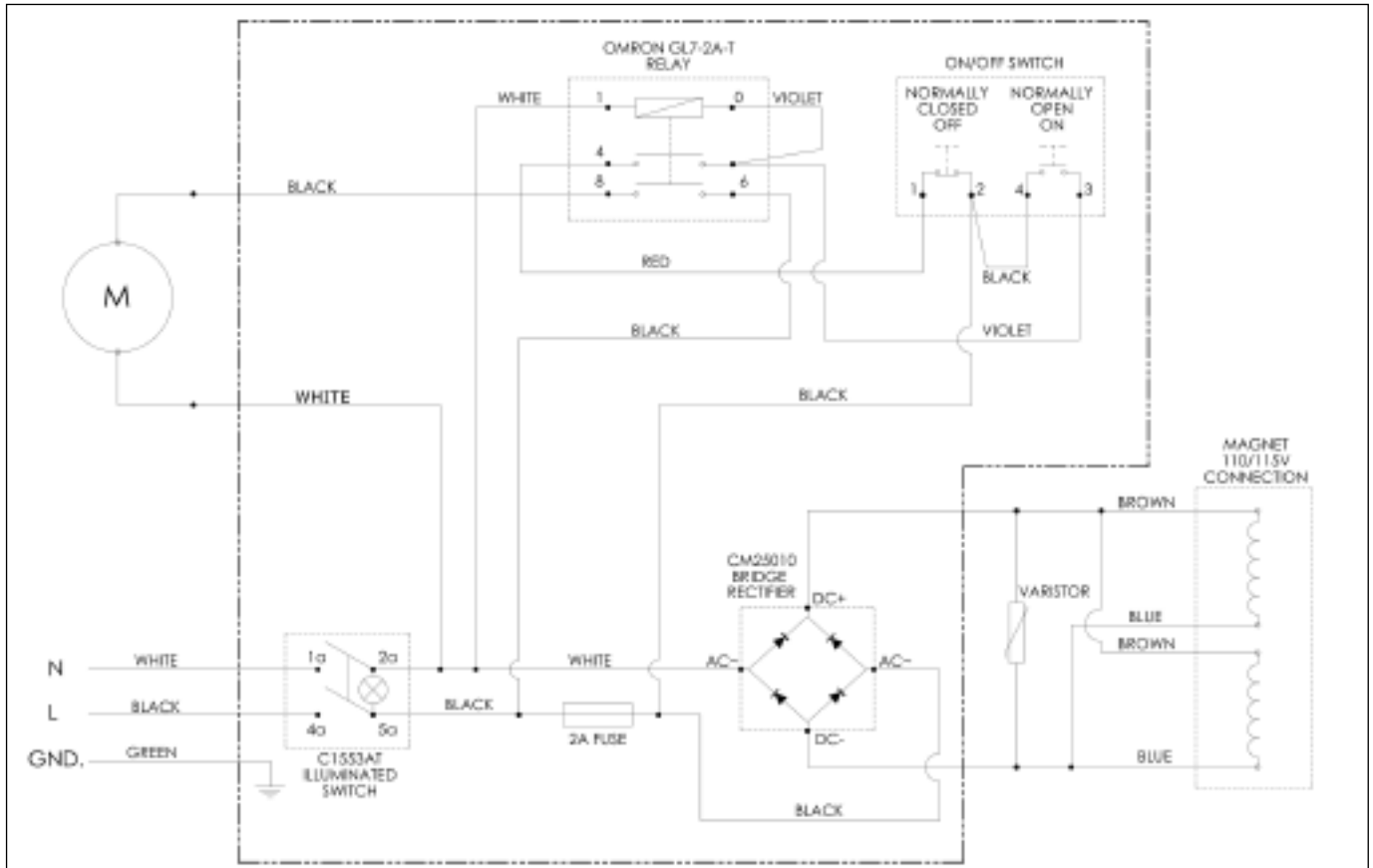

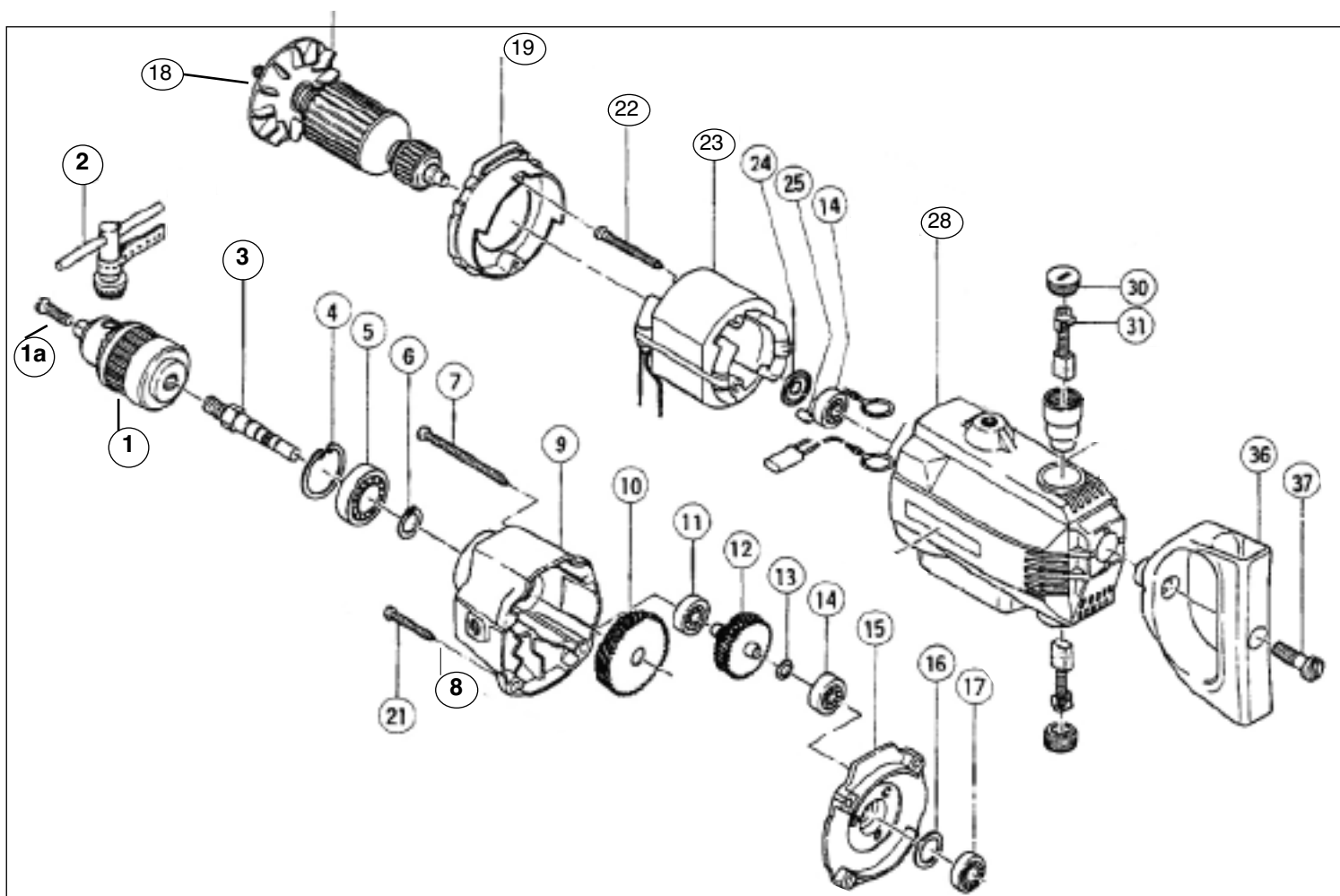

No. List/Size Description (Qty per Machine)

- 1 RB3212 1/2" Jacobs Chuck (1)
- 1a RB32-1122 Drill chuck safety screw
- 2 RB3212-KEY Chuck Key (1)
- 3 RB32-1667 Spindle (1)
- 4 RB32-9556 D35 Retaining Ring
- 5 RB32-6202V Ball Bearing
- 6 RB32-9544 D15 Retaining Ring
- 7 RB32-7725 Tapping Screw D5X70 (1)
- 8 RB32-9454 D5 Spring Washer (4)
- 9 RB32-1650 Gear Cover (1)
- 10 RB32-3448 Final Gear
- 11 RB32-627V Ball Bearing
- 12 RB32-652Z Second Pinion Assembly
- 13 RB32-9426 D8 Washer
- 14 RB32-608V Ball Bearing

No. List/Size Description (Qty per Machine)

- 15 RB32-2791 Inner Cover Assembly (1)
- 16 RB32-984357 Washer
- 17 RB32-609V Ball Bearing
- 18 RB32-657 Armature (1)
- 19 RB32-1562 Fan Guide (1)
- 21 RB32-1875 Tapping Screw D5X35 (2)
- 22 RB32-1007 Tapping Screw D5x60 (2)
- 23 RB32-797 Stator Field Coil (1)
- 24 RB32-4367 Dust Seal
- 25 RB32-6362 Bearing Lock
- 28 RB32-HAD13 Housing Assembly (1)
- 30 RB32-1781 Brush Caps (2)
- 31 RB32-612 Carbon Brush (set) (2)
- 36 RB32-794Z D-Handle (1)
- 37 RB32-796Z Special Bolt M10 for RB32-796Z (1)

- RB522 Varistor (1)
- RB326 Relay Bracket & 523 Clip (1)
- RB32-8002 Field Coil Connect #26 (1)
- RB32-8012 Field Coil Connect #27 (1)
- RB5620 D5/25 Tap Screws
- RB32-5075 M5X15 Pin Retaining Screw



RB32

Visit www.championcuttingtool.com
for 3-D imaging, zoom and and rotate.

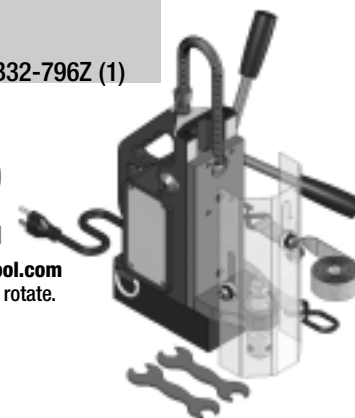

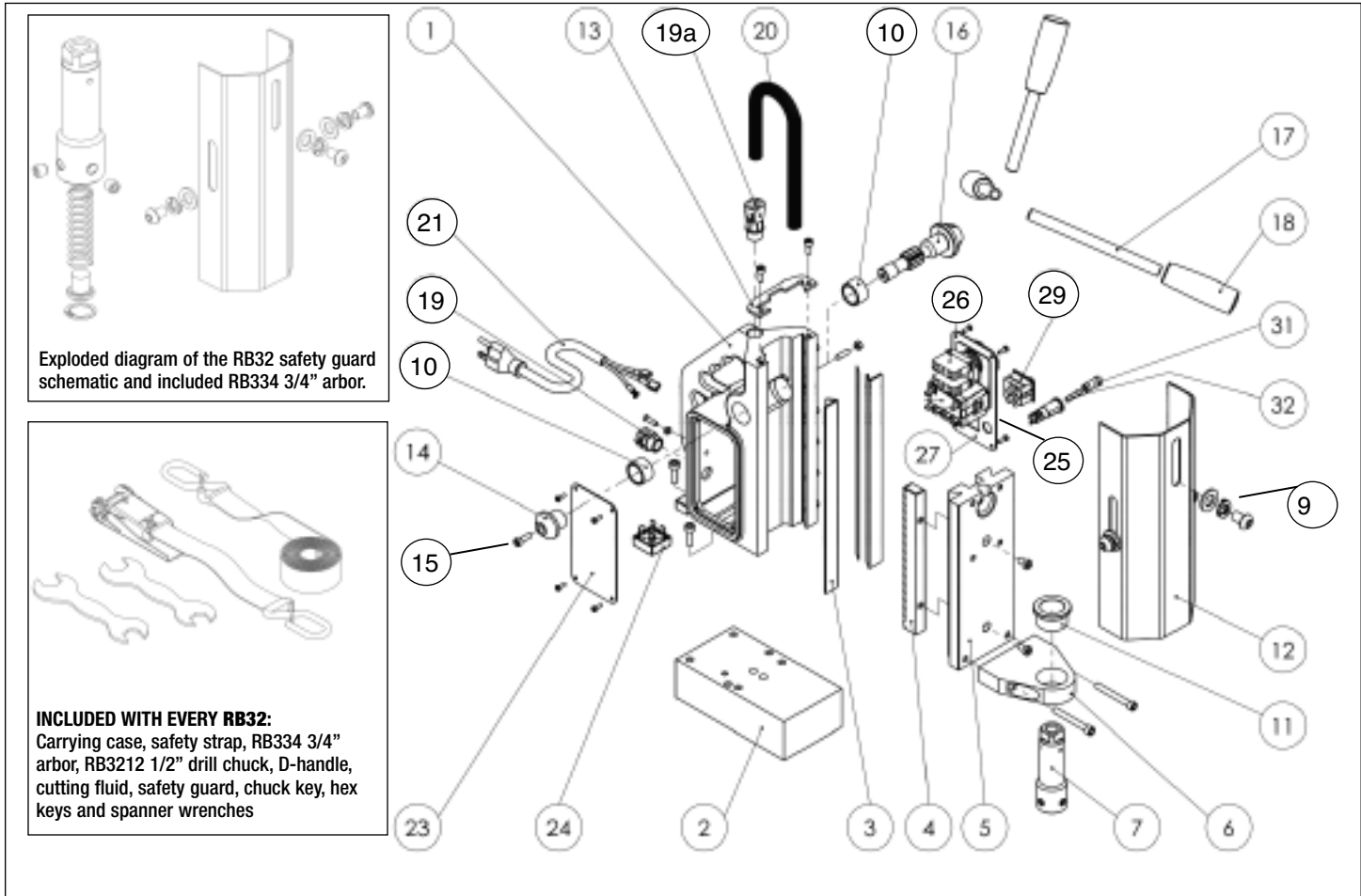

No. List/Size Description (Qty per Machine)

1	RB301	Main Body Casting (1)
2	RB302	Magnetic Base (1)
3	RB312	Brass Guides (2)
4	RB322	Machine Rack (1)
5	RB304	Dovetail Slide (1)
6	RB308	Arbor Support Bracket (1)
7	RB334	1/2-20 Threaded mount to 3/4 Arbor (1)
9	RB208	Safety Guard Screws / Washers
10	RB500	Pinion Bushing (2)
11	RB309	Spindle Bush (1)
12	RB310	Safety Guard (1)
13	RB311	Retaining Bracket (1)
14	RB524	Pinion Cap (1)
15	RB221	Cap Head Screw for Pinion M5x15 (2)
16	RB313	Pinion Shaft (1)
17	RB314	Handle (3)
18	RB508	Handle Knob (3)
19	RB519	Cable Gland for Power Cord (1)
19A	RB519A	Cable Gland for Conduit Lead (2)
20	RB504	Conduit Lead (1)
21	RB503	Mains Cable 110V (1)
23	RB316	Side Panel (1)
24	RB515	Rectifier Unit (1)
25	RB315	Switch Panel (1)
26	RB509	Stop/Start Switch (1)

No. List/Size Description (Qty per Machine)

27	RB513	Power Relay 110V (1)
29	RB505	Mag Switch 110V (1)
31	RB511	Fuse Holder (1)
32	RB512	2A Fuse (1)
RB31225	D2.5X11/16 Screw Nut RB32 Guide	
RB32-252	Panel Screws	
RB329	Shim Strip Brass Guides	
RB500	Pinion Bush	
RB516	Cutting Fluid Bottle (Empty)	
RB527	Complete Motherboard RB32	
RB9424	D5 Washer for RB5620 Screw	
RB32-6X40	Cap Head Screw Arbor Support 6X40 (2)	
RB32-CASE-MT	Empty Carrying Case	
SPANNER	7/16 & 17mm Wrenches (set of 2)	
RB32-MANUAL	User Manual N/C	
RB-POUCH	Tool Pouch	
RB-STRAP	Ratchet Safety Strap	



PORTABLE METAL DRILLING SYSTEMS

MAGNETIC DRILL PRESS RANGE



RB32 MINIBRUTE



RB45 MIGHTIBRUTE



RB65 MEGABRUTE



AC35

ANNULAR CUTTER RANGES

CT SERIES

CARBIDE TIPPED ANNULAR CUTTERS

CT150 / CT200 / CT300 / CT400

CT150

1-3/8"
Depth of cut

CT200

2" Depth of cut

CT300

3" Depth of cut

CT400

4" Depth of cut

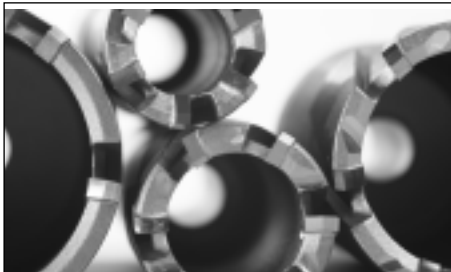

XL SERIES

HIGH SPEED ANNULAR CUTTERS

XL / XLT / XLSTK

XL

HS ANNULAR CUTTER
XL100/XL200/XL300
1" / 2" / 3"
Depth of cut



XLT

HS TITANIUM COATED
XL100T / XL200T
1" / 2" Depth of cut



XLSTK

COBALT STACK CUT
XL200STK
2" Depth of cut



P.O.Box 368, Rockville Centre, NY 11571-0368

Tel: 516-536-8200 Fax: 516-536-8186

www.championcuttingtool.com